

Easy-to-connect stop valve integrated with Super 300 Type PILLAR FittingTM



■ Features

■ Excellent chemical resistance

The wetted parts are made of PFA or PTFE, enabling this product to cope with various types of liquid chemicals.

■ Rich lineup of products in different sizes

Our products support 6 to 25 mm or 1/4" to 1-1/2" diameter tubes.

Specifications

- ▶ Maximum operating temperature: 100°C
(50°C for 1-1/4" and 1-1/2" diameter tubes)
- ▶ Maximum operating pressure: 0.7 MPaG
- ▶ Applicable fluid: Liquid
- ▶ Ambient temperature range: 0 to 60°C
(0 to 50°C for 1-1/4" and 1-1/2" diameter tubes)
- ▶ Operating method: Manual

■ Operating range

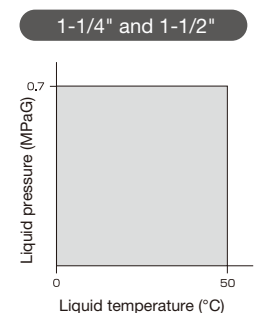
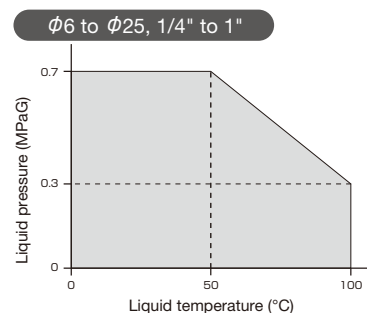

PILAFLON™ Stop Valve PSV series

Cross-sectional structural drawing ($\phi 6$ to $\phi 25$, 1/4" to 1")

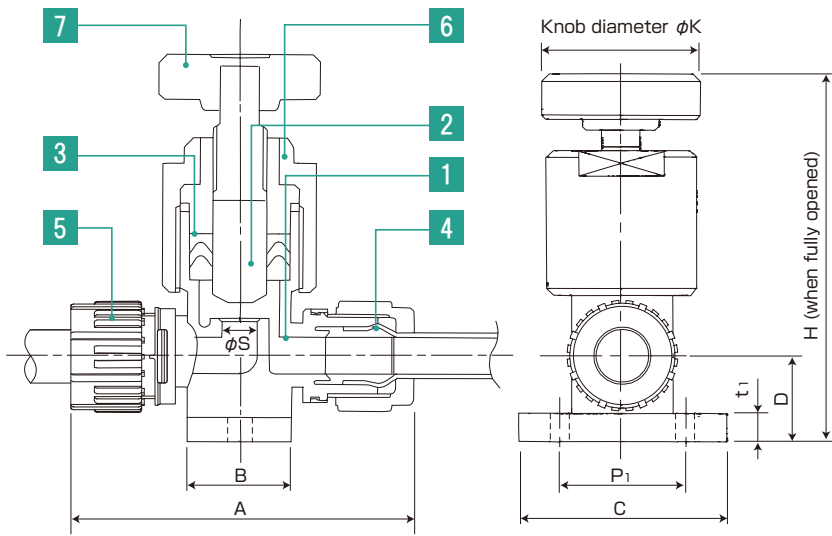

PSV-P06B to P12B PSV-PW2B to PW4B

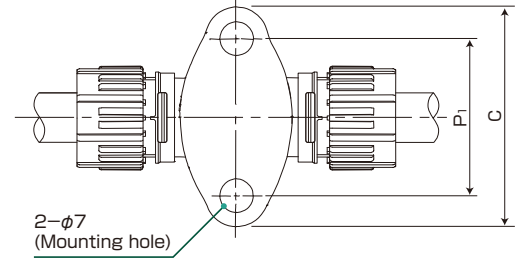

PSV-P19B, P25B PSV-PW6B, PW8B

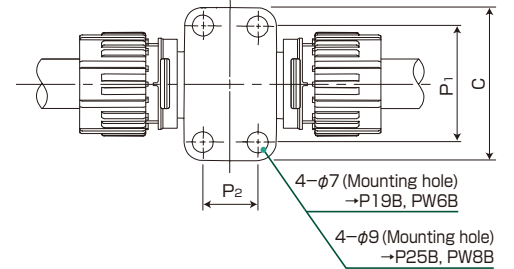

Main parts list

Parts	No.	Part name	Material	Parts	No.	Part name	Material
Wetted parts	1	Valve body	PFA	Non-wetted parts	5	Union nut	PFA
	2	Stem	PFA		6	Outer ring	P.P
	3	V-ring set	PTFE		7	Knob	P.P
	4	Sleeve	PFA				

Size table

Unit: mm

mm-based tube												
Product No.	Tube size (O.D×I.D)	H (when fully opened)	A	B	C	D	t ₁	P ₁	P ₂	Knob diameter φK	Orifice diameter φS	
PSV-P06B	6×4	79	64	17	43	16	5	31	—	30	4	
PSV-P08B	8×6	84.5	72	19	44	17.5	5	32	—	30	5	
PSV-P10B	10×8	94	84	24	51	21	7	38	—	35	7	
PSV-P12B	12×10	104	95	27	55	23	7	42	—	42	9	
PSV-P19B	19×15.8	121	119	36	60	28	7	46	22	50	14	
PSV-P25B	25×22	151	148	50	79	33	7	62	33	70	20	
Inch-based tube												
Product No.	Tube size (O.D×I.D)	H (when fully opened)	A	B	C	D	t ₁	P ₁	P ₂	Knob diameter φK	Orifice diameter φS	
PSV-PW2B	6.35×3.95	79	64	17	43	16	5	31	—	30	4	
PSV-PW3B	9.53×6.33	94	84	24	51	21	7	38	—	35	7	
PSV-PW4B	12.7×9.5	104	95	27	55	23	7	42	—	42	9	
PSV-PW6B	19 ×15.8	121	119	36	60	28	7	46	22	50	14	
PSV-PW8B	25.4×22.2	151	148	50	79	33	7	62	33	70	20	

Cross-sectional structural drawing (1-1/4" and 1-1/2")

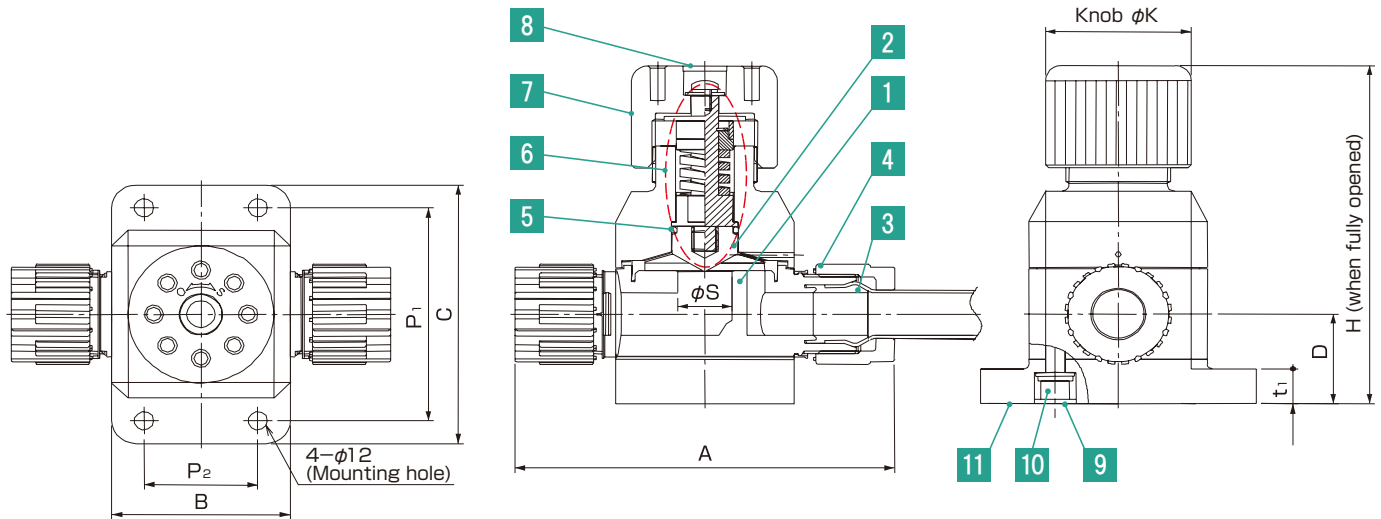

Main parts list

Parts	No.	Part name	Material
Wetted parts	1	Valve body	PTFE
	2	Diaphragm	PTFE
	3	Sleeve	PFA
Non-wetted parts	4	Union nut	PFA
	5	O-ring	FR
	6	Stem set	SUS
	7	Knob	P.P
	8	Cap A	FR
	9	Cap B	FR
	10	Through-bolt	SUS (Fluorine coating)
	11	Base	P.P

Valve open/close handle

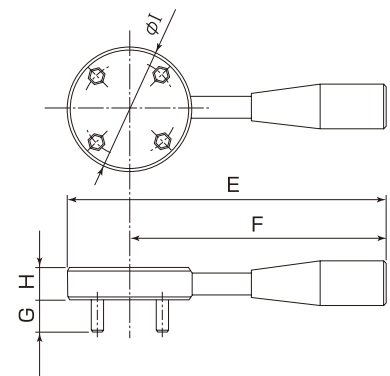

Size table

Unit: mm

Product No.	Tube size			H (when fully opened)	A	B	C	D	t ₁	P ₁	P ₂	Knob diameter φK	Orifice diameter φS
	O.D×I.D	Tolerance											
		O.D.	Thickness										
PSV-PW10SA	31.8×28.0 (1-1/4" × 1-1/10")	±0.25	±0.15	222	234	110	170	59	23	140	70	90	28.0
PSV-PW12SA	38.1×33.7 (1-1/2" × 1-21/64")	±0.25	±0.15	228	234	110	170	62	23	140	70	90	33.7

Valve open/close handle		Handle size (mm)					Material
		E	F	G	H	φ I	
P-VH		203	163	20	20	80	Aluminum/stainless steel (Grip part: Phenolic resin)



PILLAR PILLAR Corporation
CLEAN SAFETY FRONTIER

Head office/Sales Headquarters
7-1, Shinmachi 1-chome, Nishi-ku, Osaka 550-0013, Japan
Phone: +81-6-7166-8326 Fax: +81-6-7166-8514

Email : sales@pillar.co.jp

<https://www3.pillar.co.jp/en/product/>



● When using this product, please use correctly and pay sufficient attention to safety.

* Please understand that this catalog may change without prior notice.
* The values shown on this catalog are reference values, not guaranteed values.