

Clean pump with all wetted parts made of fluorocarbon polymers
 Separately arranged accumulator can reduce pulsation

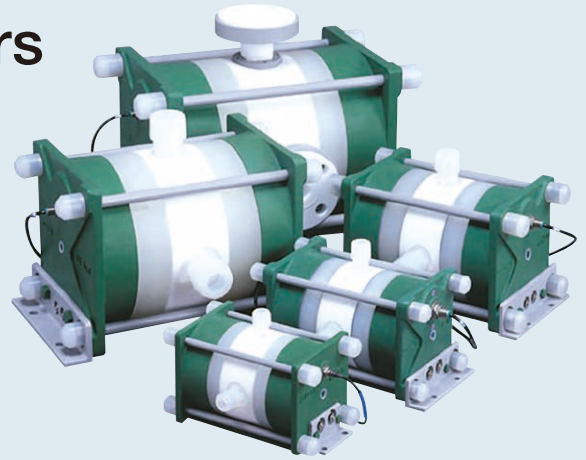

High-quality bellows

The PE series bellows pump employs special PTFE bellows with excellent flex life, and the bent portion of the bellows is rounded to achieve long service life. We manufacture this product in our own cleanrooms using our integrated production system from molding through to processing and assembly. Each bellows is assigned a serial number to manage all materials.

Method for sealing the contact surface of the bellows and body

The PE series bellows pump employs the lip sealing structure, ensuring high surface pressure with line contact, to prevent liquid leakage caused by creep of each resin.

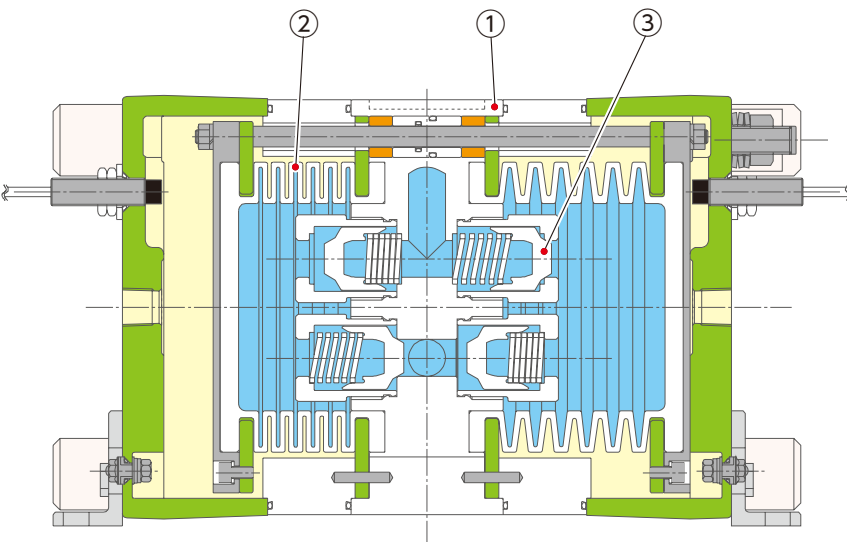

Air-driven part with a sealing structure

The PE series bellows pump employs an internally developed maintenance-free dry sliding slipper ring that uses no grease and provides excellent self-lubricating capabilities. It uses high-performance fluoro-resin materials developed by applying technologies that we, as a fluid seal manufacturer, have cultivated over many years.

Maintainability

The PE series bellows pump is structured to allow component replacement, which means that it can be reused after repair. This also contributes to solving environmental issues.

Shape of bent portion

Rounded shape

The bent portion is rounded by special processing to distribute stress

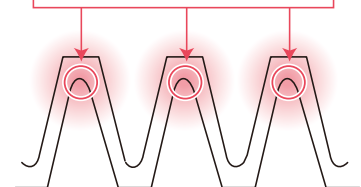

Wetted parts

No.	Part	Material
①	Body	All wetted parts employ fluorocarbon polymers with excellent chemical resistance (PTFE or PFA).
②	Bellows	
③	Check valve	

The figure on the left shows the cross-sectional view of PE-10MA to PE-80MA.

PE-5MA, PE-10MA, PE-20MA, PE-40MA, PE-80MA



Dimensions

	A	B	(C)	D	E	(F)	G	H	J	K
PE-5MA	236	218	156	122	50	160	126	65	Rc1/4	4-φ9
PE-10MA	284	266	180	142	65	185	147	76		
PE-20MA	324	304	231	184	80	234	187	95	Rc3/8	4-φ11
PE-40MA	404	376	302	245	120	307	249.5	112		
PE-80MA	538	478	342	277	130	359	286.5	129	Rc1/2	4-φ13

Unit: mm

Structural drawings

PE-5MA, PE-10MA, PE-20MA, PE-40MA

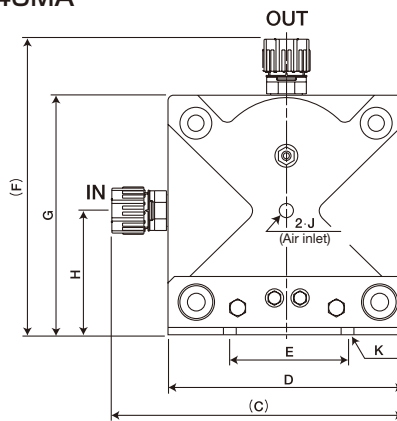
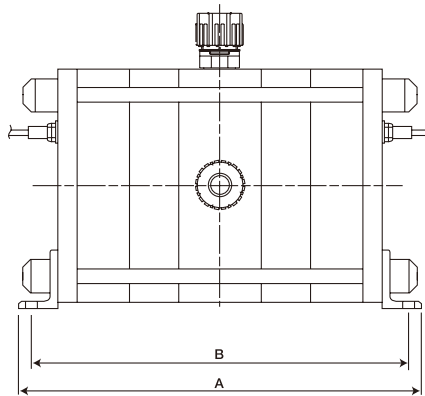

PE-80MA

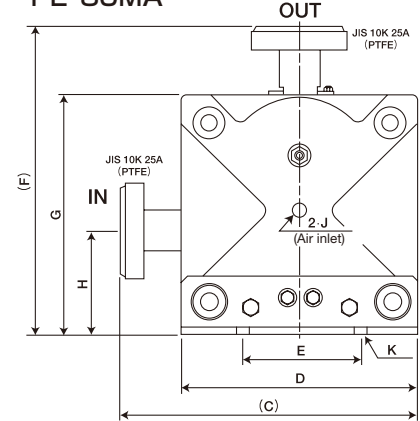

Specifications

Model		PE-5MA		PE-10MA		PE-20MA		PE-40MA		PE-80MA			
Pump connection size*1	mm	IN φ10 / OUT φ10		IN φ12 / OUT φ12		IN φ19 / OUT φ19		IN φ25 / OUT φ25		IN, OUT JIS 10K 25A FLANGE*2			
Pump connector		Super 300 Type PILLAR Fitting™											
Max discharge capacity	L/min	8		16		32		60		82			
Operating temperature	°C	10 to 40	41 to 100	10 to 40	41 to 100	10 to 40	41 to 100	10 to 40	41 to 100	10 to 40	41 to 60	61 to 80	
Supply air pressure	MPaG	0.2 to 0.5	0.2 to 0.4	0.2 to 0.5	0.2 to 0.4	0.2 to 0.5	0.2 to 0.4	0.2 to 0.5	0.2 to 0.4	0.2 to 0.5	0.2 to 0.4	0.2 to 0.3	
Max discharge pressure	MPaG	0.45	0.35	0.45	0.35	0.45	0.35	0.45	0.35	0.45	0.35	0.25	
Allowable differential pressure of bellows*3	MPa	0.4	0.3	0.4	0.3	0.4	0.3	0.4	0.3	0.3	0.25	0.2	
Discharge capacity per stroke*4	L	0.09		0.21		0.41		0.85		1.69			
Air consumption	L/min (Normal)	25 to 225		30 to 340		30 to 450		50 to 630		100 to 650			
Ambient temperature	°C	10 to 50											
Effective cross-sectional area of solenoid valve	mm ²	27 or more		27 or more		27 or more		57 or more		57 or more			
Air inlet ports		2-Rc1/4		2-Rc1/4		2-Rc3/8		2-Rc3/8		2-Rc1/2			
Supply air pipe length	m	2 or less	2 to 5	5 or more	2 or less	2 to 5	5 or more	2 or less	2 to 5	5 or more	2 or less	2 to 5	5 or more
Supply air pipe inside diameter	mm	6 or more	7 or more	★	8 or more	9 or more	★	8 or more	9 or more	★	10 or more	12 or more	★
Weight	kg	Approx. 5		Approx. 8		Approx. 15		Approx. 29		Approx. 47			
Pump size (excluding piping) A×D×G*5	mm	236×122 ^H ×126 ^H		284×142 ^H ×147 ^H		324×184 ^H ×187 ^H		404×245 ^H ×249.5 ^H		538×277 ^H ×286.5 ^H			

*1: To obtain performance with this pump, pipes with the pump connection size shown above are required. Install the pump so that the length of the suction pipe does not exceed two meters.

*2: In addition to the flange type, our Super 300 Type PILLAR Fitting is also available. Please contact us for further details.

*3: Allowable differential pressure of bellows = Air supply pressure - Discharge pressure

*4: This is a reference value. Make sure that the stroke speed is always 80 spm or lower (60 spm or lower for the PE-80MA).

*5: The pump size is a reference value.

★ Please contact us for details.

Notes 1) If the fluid to be used requires anti-explosion treatment because it is an organic or similar liquid, anti-explosive pumps with proximity sensors are available. Please consult with us separately for more information.

2) If the fluid to be used is CMP slurry, we recommend the "PC series slurry pump" dedicated to use with CMP slurry.

Temperature: 20°C

• PE-5MA •

Temperature: 80°C

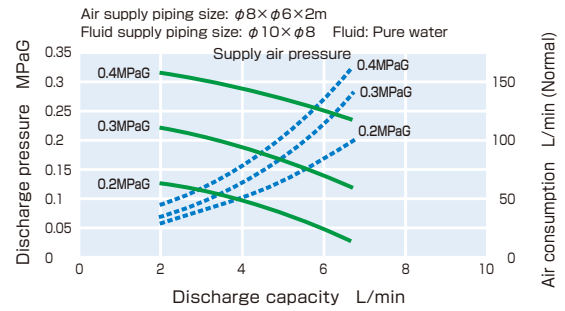
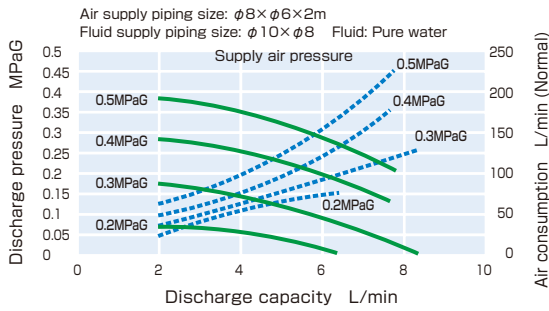

Temperature: 20°C

• PE-10MA •

Temperature: 80°C

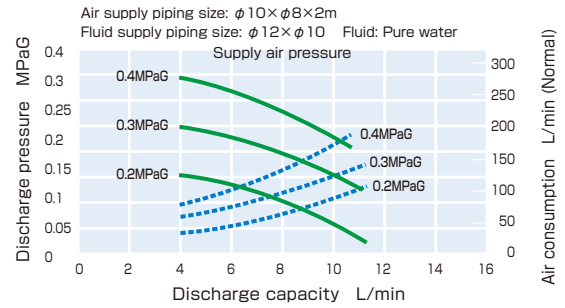
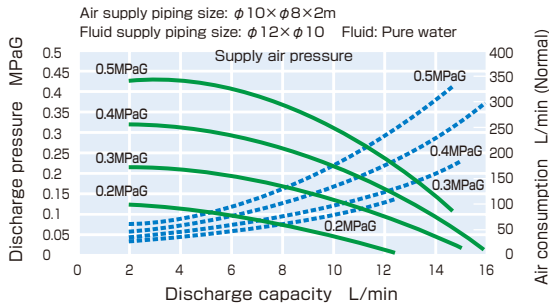

Temperature: 20°C

• PE-20MA •

Temperature: 80°C

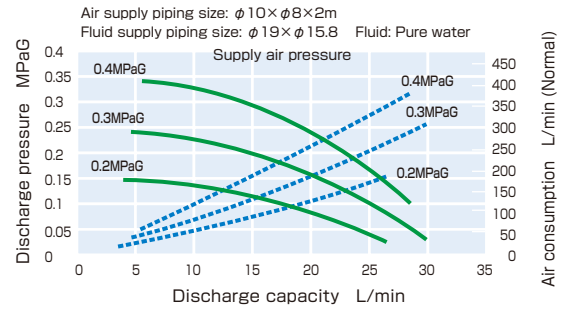
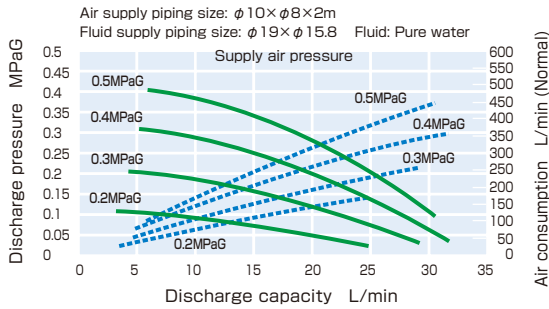

Temperature: 20°C

• PE-40MA •

Temperature: 80°C

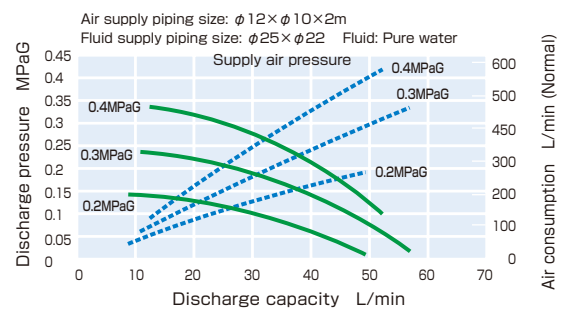
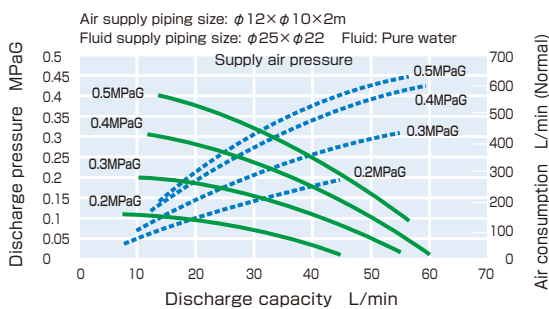

Temperature: 20°C

• PE-80MA •

Temperature: 80°C

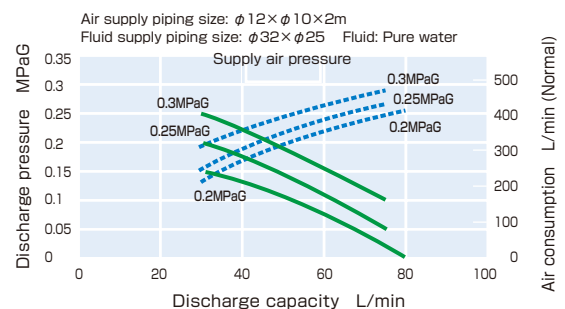
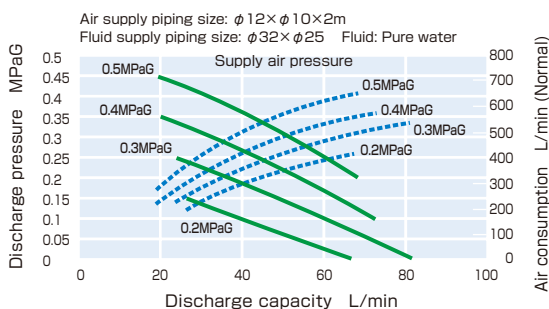

PE-10HB, PE-20HB, PE-40HBH

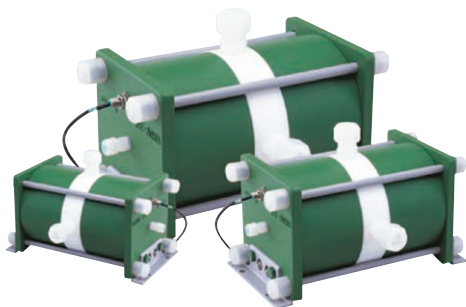

Dimensions

Unit: mm

	A	B	(C)	D	E	(F)	G	H	J	K
PE-10HB	304	282	193	152	70	196	156	80	Rc1/4	4-φ11
PE-20HB	360	340	241	190	100	245	194	99	Rc3/8	4-φ11
PE-40HBH	404	376	314	254	120	316	256	112	Rc3/8	4-φ13

Structural drawings

PE-10HB, PE-20HB, PE-40HBH

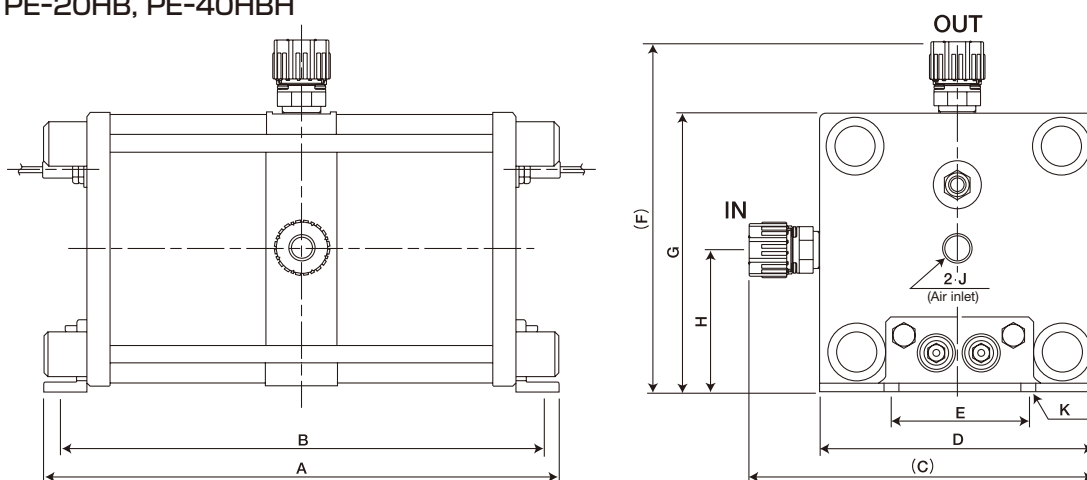

Specifications

Model		PE-10HB				PE-20HB				PE-40HBH							
Pump connection size*1	mm	IN φ1/2" / OUT φ1/2"								IN φ3/4" / OUT φ3/4"				IN φ1" / OUT φ1"			
Pump connector		Super 300 Type PILLAR Fitting™															
Max discharge capacity	L/min	16				32				64							
Operating temperature	°C	10 to 40	41 to 100	101 to 140	141 to 180	10 to 40	41 to 100	101 to 140	141 to 180	10 to 40	41 to 100	101 to 140	141 to 180				
Supply air pressure	MPaG	0.2 to 0.5	0.2 to 0.4	0.2 to 0.3	0.15 to 0.2	0.2 to 0.5	0.2 to 0.4	0.2 to 0.3	0.15 to 0.2	0.2 to 0.5	0.2 to 0.4	0.2 to 0.3	0.15 to 0.2				
Max discharge pressure	MPaG	0.45	0.35	0.25	0.15	0.45	0.35	0.25	0.15	0.45	0.35	0.25	0.15				
Allowable differential pressure of bellows*2	MPa	0.4	0.3	0.2	0.15	0.4	0.3	0.2	0.15	0.4	0.3	0.2	0.15				
Discharge capacity per stroke*3	L	0.21				0.42				0.86							
Air consumption	L/min (Normal)	20 to 400				20 to 470				20 to 700							
Ambient temperature	°C	10 to 50															
Effective cross-sectional area of solenoid valve	mm²	27 or more				27 or more				57 or more							
Air inlet ports		2-Rc1/4				2-Rc3/8				2-Rc3/8							
Supply air pipe length	m	2 or less	2 to 5	5 or more		2 or less	2 to 5	5 or more		2 or less	2 to 5	5 or more					
Supply air pipe inside diameter	mm	8 or more	9 or more	★		8 or more	9 or more	★		10 or more	12 or more	★					
Weight	kg	Approx. 10				Approx. 21				Approx. 38							
Pump size (excluding piping) A×D×G*4	mm	304×152×156 ^H				360×190×194 ^H				404×254×256 ^H							

*1: To obtain performance with this pump, pipes with the pump connection size shown above are required. Install the pump so that the length of the suction pipe does not exceed two meters.

*2: Allowable differential pressure of bellows = Air supply pressure - Discharge pressure

*3: This is a reference value. Make sure that the stroke speed is always 80 spm or lower.

*4: The pump size is a reference value.

★ Please contact us for details.

Notes 1) If the fluid to be used requires anti-explosion treatment because it is an organic or similar liquid, anti-explosive pumps with proximity sensors are available. Please consult with us separately for more information.

2) If the fluid to be used is CMP slurry, we recommend the "PC series slurry pump" dedicated to use with CMP slurry.

■ Performance curve

H-Q characteristics Air consumption

Temperature: 130°C

• PE-10HB •

Temperature: 180°C

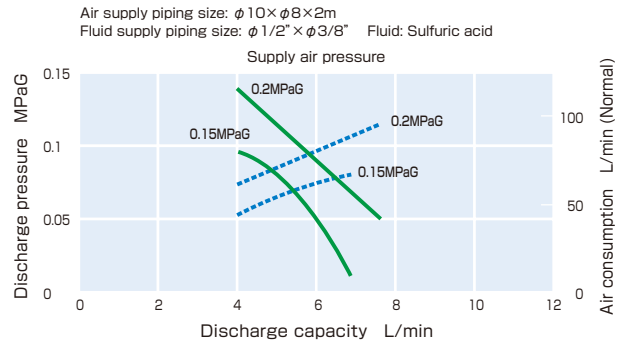
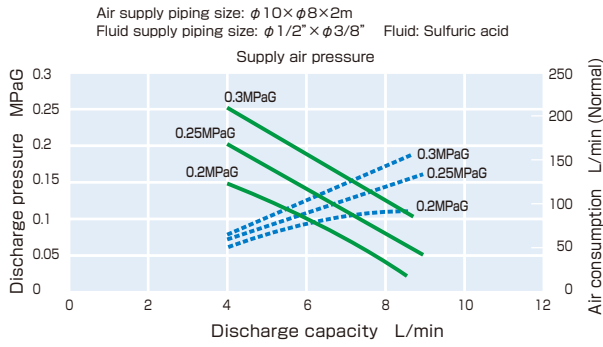

Temperature: 130°C

• PE-20HB •

Temperature: 180°C

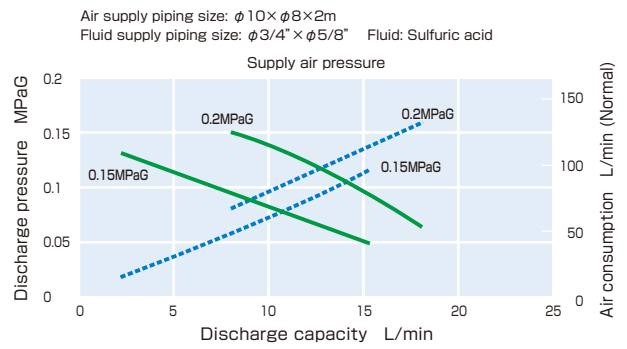
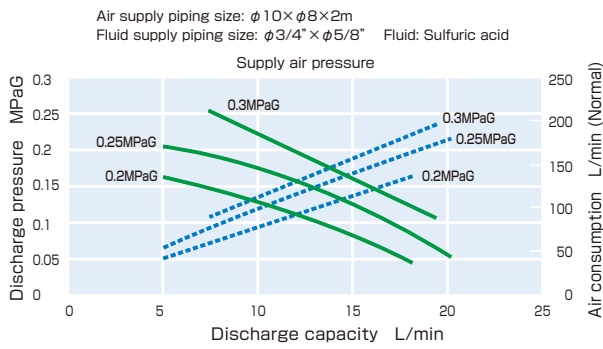

Temperature: 130°C

• PE-40HBH •

Temperature: 180°C

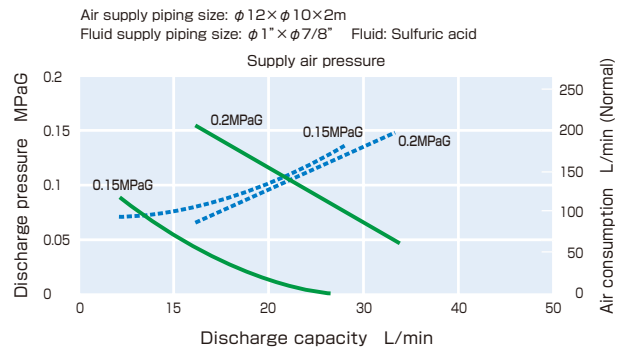
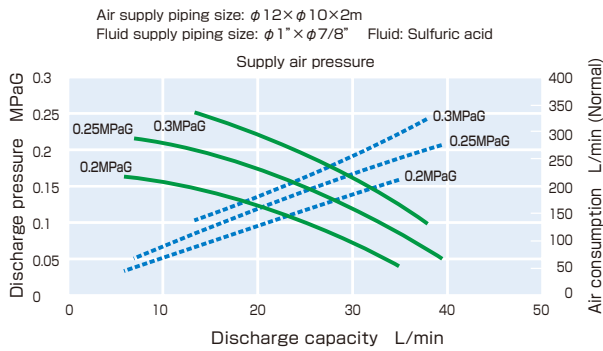

PA Series Auto Accumulator

The accumulator allows air pressure to automatically follow bellows pump pressure fluctuations, reducing the pulse pressure.

All wetted parts employ fluorocarbon polymers (PTFE or PFA).

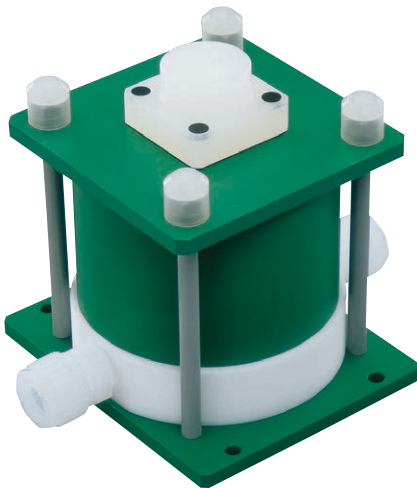

Example of use

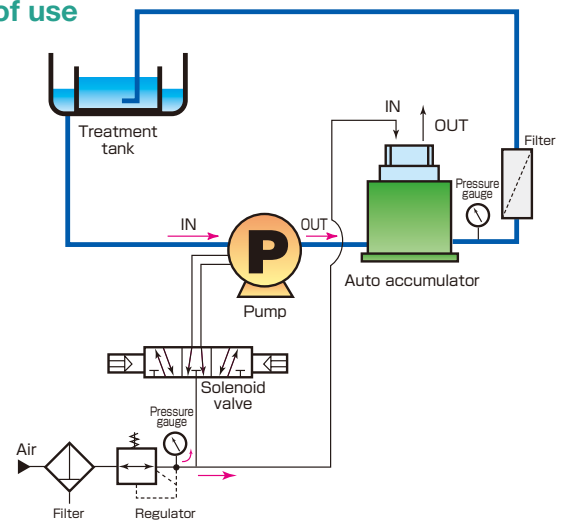

Specifications

Model	PA-10HB	PA-20HB	PA-40HB	PA-80MB
Applicable pumps	PE-5MA PE-10MA PE-10HB	PE-20MA PE-20HB	PE-40MA PE-40HBH	PE-80MA
Liquid connection size	$\phi 12 \times \phi 10$	$\phi 19 \times \phi 15.8$	$\phi 25 \times \phi 22$	
Liquid connector	Super 300 Type PILLAR Fitting™			
Operating temperature	10 to 180°C			10 to 80°C
Operating pressure*	0 to 0.45 MPa			
Supply air pressure*	0.2 to 0.5 MPa			
Pulsation pressure range	Within $\pm 12.5\%$ of the pump discharge pressure when it is 0.16 MPaG or more 0.04 MPa or lower when the pump discharge pressure is less than 0.16 MPaG			
Air inlet ports	Rc 1/4			
Weight (kg)	Approx. 3.5	Approx. 8	Approx. 9.5	Approx. 13.5

* The operating pressure range and supply air pressure differ according to the applicable pump or operating temperature. Before using the product, please check the relevant sections in the operation manual.

Example of use in a semiconductor factory

PILLAR products such as pumps, fittings, and valves are widely used in semiconductor and LCD factories.

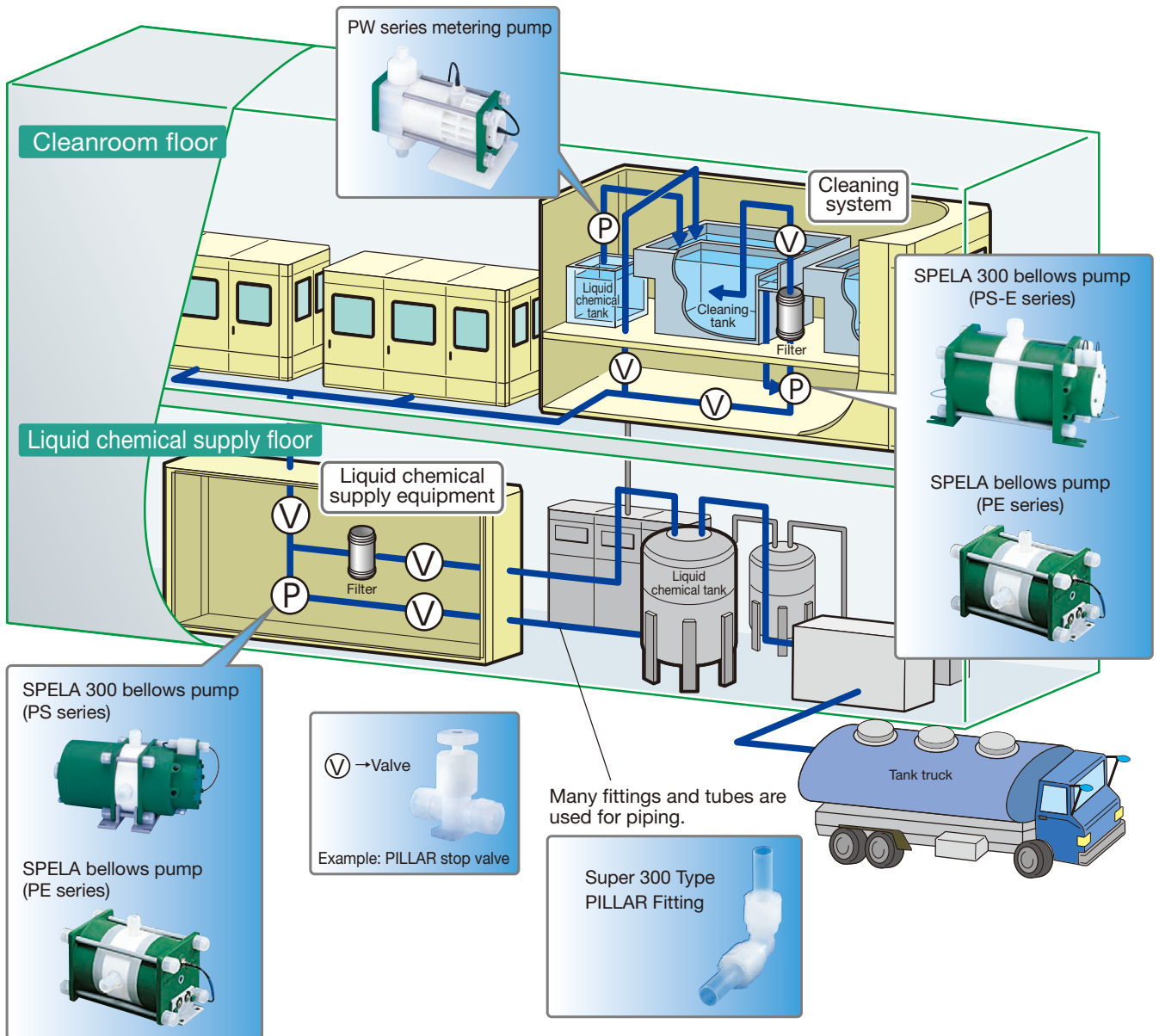



PILLAR PILLAR Corporation
CLEAN SAFETY FRONTIER

Head office/Sales Headquarters
7-1, Shinmachi 1-chome, Nishi-ku, Osaka 550-0013, Japan
Phone: +81-6-7166-8326 Fax: +81-6-7166-8514

Email : sales@pillar.co.jp

<https://www3.pillar.co.jp/en/product/>



**Safety
precaution**

● When using this product, please use correctly and pay sufficient attention to safety.

* Please understand that this catalog may change without prior notice.
* The values shown on this catalog are reference values, not guaranteed values.